

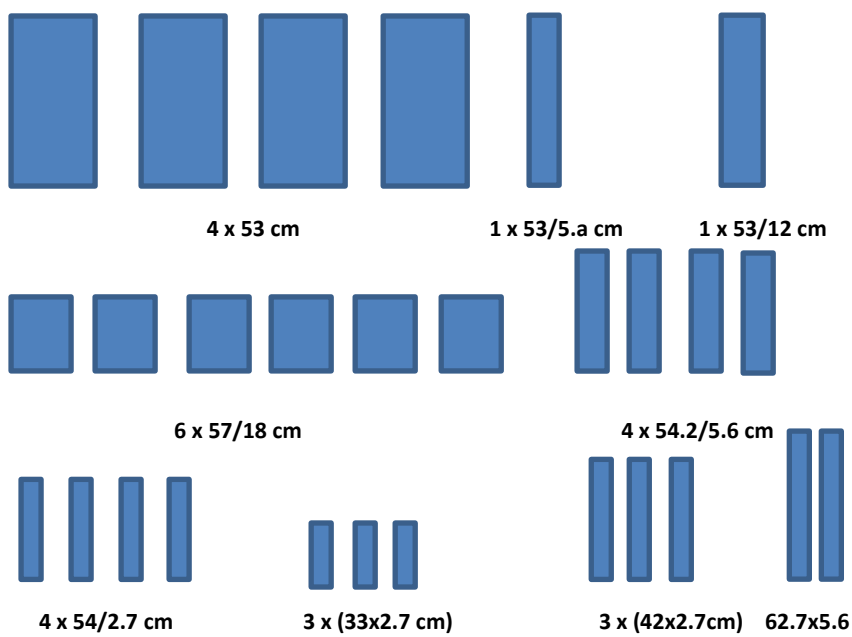

Thanks for purchasing the Vlieland chair!

In this manual we explain step by step how to assemble the chair.



### What do you need?

- Power tool
- Drill (we advise size 4)
- Sandpaper (we advise p 100)
- Tape measure

Step 1: **Sandpaper**, sandpaper both sides of the planks.

### Step 2: **Sidepanels**

You need the following planks/slats:

- 6 x 18 x 57 cm
- 2 x 5.6 x 62.7 cm
- 4 x 3 x 54 cm
- 4 x 5.6 x 54.2 cm

Laydown 3 planks (18x57cm) next to each other. Place 2 slats (54x3cm) on the sides of the planks. Drill the holes and mount them.

Laydown 2 slats (54x5.6cm) on the mounted planks. Drill holes and mount them. Take a slat (63.7x5.6cm) Mount them on 2 sides of the beams you just mounted.

Repeat this procedure to assemble a second side panel.

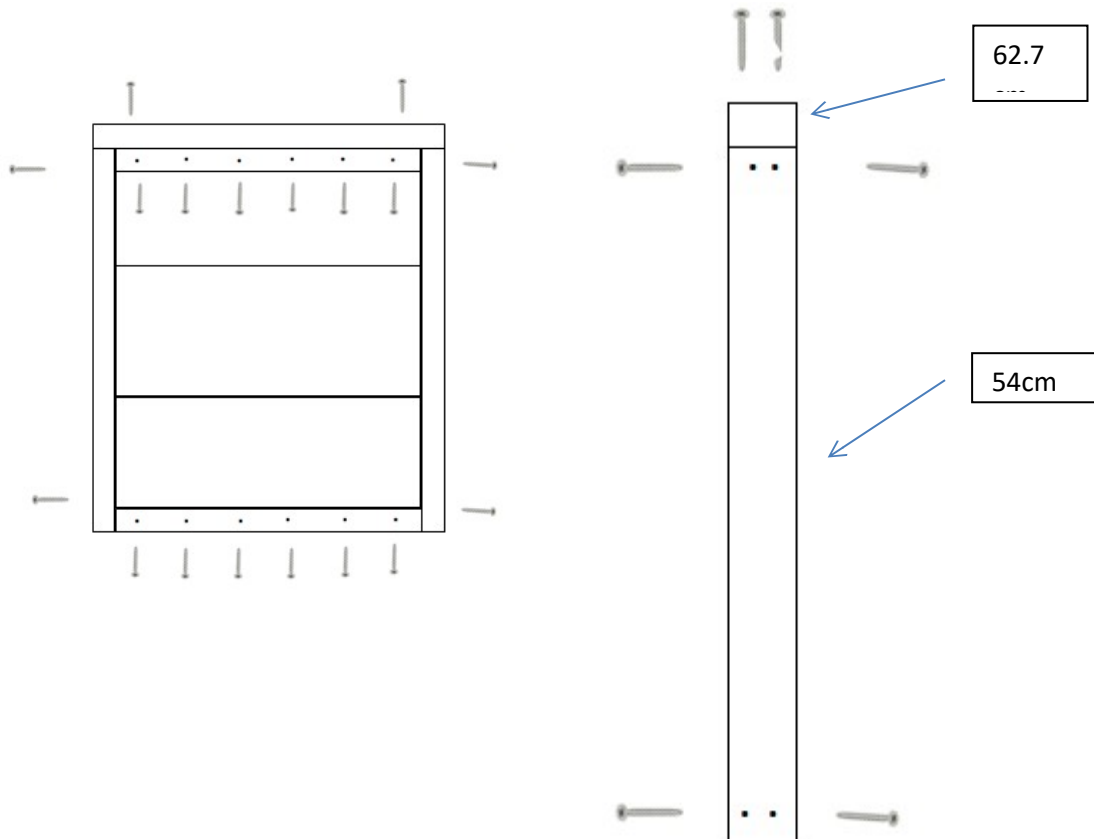

### Step 3 : The seating

You need the following planks/slats:

- 2 x 53 x 18 cm
- 1 x 53 x 12 cm
- 1 x 53 x 5 cm

- 3 x 42 x 2.7 cm

Put down 2 planks (53x18cm) and 1 plank (53x12) next to each other. Put the widest plank on the outside. Drill the holes and put them between the 2 side panels.

Laydown a slat (53x5cm) under the first plank of the seating. Laydown the slat (42x2.7cm) in the centre and mount it. (this is a support beam)

Laydown 2 slats (42x2.7cm) on the sides. Mount them with 6 Phillip heads through the seating surface in to the beam. Mount the beams to the sidepanels with 4 phillip heads.

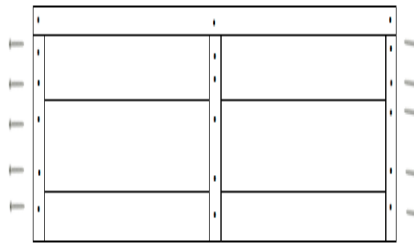

**Bottom view**



**Front view**

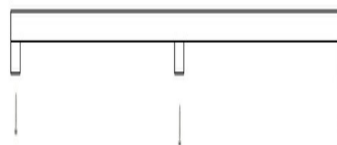

**rear view**

#### Step 4: **The backrest**

You need the following planks/slats:

- 2 x 53 x 18 cm

- 3 x 33 x 2.7 cm

Place 2 planks (53x18cm) on top of each other. Laydown 3 slats (33x2.7) on these planks (see picture). Drill on the top of the slat 4 holes. ( Holes have to be scatterd through the length of the slat)

Repeat this with the other 2 slats.

To mount the backpiece on the seating, you have to drill 3 holes on the inside of the 2 outer slats. (this 3 phillip heads aren't in the picture)

They are needed to mount the backrest to the rest of the chair. Make sure the phillip heads don't touch each other!

rear view

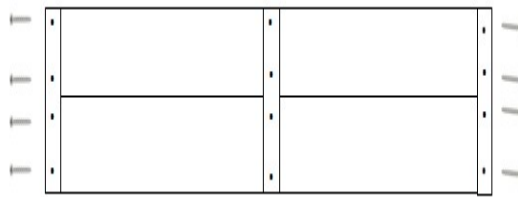

Top view

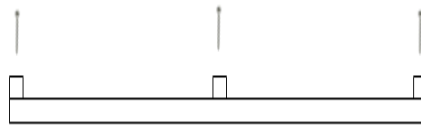

Make sure you mount the backrest with a seat depth of 44cm. Mount this with 3 phillip heads on each side of the backrest.

You finished the chair. Enjoy!

